

SMALL GENERATOR INTERCONNECTION AGREEMENT (SGIA)

(For Generating Facilities No Larger Than 20 MW)

BETWEEN

PACIFIC GAS AND ELECTRIC COMPANY

AND

CENTRAL COAST COMMUNITY ENERGY

For Project:

**Emeline
3243 - WD**

**Santa Cruz, CA 95060
Santa Cruz County**

TABLE OF CONTENTS

	<u>Page No.</u>
Article 1. Scope and Limitations of Agreement	1
1.5 Responsibilities of the Parties	1
1.6 Parallel Operation Obligations.....	3
1.7 Metering.....	3
1.8 Reactive Power.....	3
1.8.1 Power Factor Design Criteria	3
1.8.2 Deleted	4
1.8.3 Deleted	4
1.8.4 Primary Frequency Response.....	4
Article 2. Inspection, Testing, Authorization, and Right of Access	7
2.1 Equipment Testing and Inspection	7
2.2 Authorization Required Prior to Parallel Operation.....	7
2.3 Right of Access.....	8
Article 3. Effective Date, Term, Termination, and Disconnection	8
3.1 Effective Date	8
3.2 Term of Agreement	8
3.3 Termination.....	8
3.4 Temporary Disconnection	9
3.4.1 Emergency Conditions	9
3.4.2 Routine Maintenance, Construction, and Repair.....	9
3.4.3 Forced Outages.....	9
3.4.4 Adverse Operating Effects.....	10
3.4.5 Modification of the Small Generating Facility	10
3.4.6 Reconnection	10
Article 4. Cost Responsibility for Interconnection Facilities and Distribution Upgrades	10
4.1 Interconnection Facilities.....	10
4.2 Distribution Upgrades.....	11
Article 5. Cost Responsibility for Network Upgrades.....	11
5.1 Applicability	11
5.2 Network Upgrades	11
5.2.1 Repayment of Amounts Advanced for Network Upgrades	11
5.3 Special Provisions for Affected Systems	12
5.4 Rights Under Other Agreements	12
Article 6. Billing, Payment, Milestones, and Financial Security	12
6.1 Billing and Payment Procedures and Final Accounting	12
6.2 Milestones.....	13
6.3 Financial Security Arrangements	13
6.4 Responsibility for any Outstanding Interconnection Study Costs.....	14
Article 7. Assignment, Liability, Indemnity, Force Majeure, Consequential Damages, and Default	14
7.1 Assignment.....	14

7.2	Limitation of Liability	14
7.3	Indemnity	15
7.4	Consequential Damages	15
7.5	Force Majeure.	15
7.6	Default	16
Article 8. Insurance		16
Article 9. Confidentiality.....		17
Article 10. Disputes		18
Article 11. Taxes		18
Article 12. Miscellaneous		19
12.1	Governing Law, Regulatory Authority, and Rules.....	19
12.2	Amendment	19
12.3	No Third-Party Beneficiaries.....	19
12.4	Waiver	19
12.5	Entire Agreement.....	19
12.6	Multiple Counterparts.	19
12.7	No Partnership.....	19
12.8	Severability	20
12.9	Security Arrangements	20
12.10	Environmental Releases.....	20
12.11	Subcontractors	20
12.12	Reservation of Rights	21
Article 13. Notices		21

IN PROCESS

[Attachment 1](#) – Glossary of Terms

[Attachment 2](#) – Description and Costs of the Small Generating Facility, Interconnection Facilities, and Metering Equipment

[Attachment 3](#) – One-line Diagram Depicting the Small Generating Facility, Interconnection Facilities, Metering Equipment, and Upgrades

[Attachment 4](#) – Milestones

[Attachment 5](#) – Additional Operating Requirements for the Distribution Provider's Distribution and Transmission Systems and Affected Systems Needed to Support the Interconnection Customer's Needs

[Attachment 6](#) – Distribution Provider's Description of its Upgrades and Best Estimate of Upgrade Costs

This Interconnection Agreement ("Agreement") is made and entered into this _____ day of _____, 2023 by **PACIFIC GAS AND ELECTRIC COMPANY** ("Distribution Provider"), and **Central Coast Community Energy** ("Interconnection Customer"), each hereinafter sometimes referred to individually as "Party" or both referred to collectively as the "Parties."

Distribution Provider Information

Pacific Gas and Electric Company
Attention: Electric Grid Interconnection - Contract Management
300 Lakeside Drive
Oakland, CA 94612-3534
Email: EGIContractMgmt@pge.com

Interconnection Customer Information

Central Coast Community Energy
Attention: Dennis Dyc-O'neal
70 Garden Court, Ste 300
Monterey, CA 93940
Phone: (877) 455-2223
Email: ddyconeal@3ce.org

Interconnection Customer Application No: PG&E Project ID # 500755950, Queue # 3243-WD.
In consideration of the mutual covenants set forth herein, the Parties agree as follows:

Article 1. Scope and Limitations of Agreement

- 1.1 This Agreement shall be used for all Small Generating Facility Interconnection Requests submitted under the Small Generator Interconnection Procedures (SGIP) or Generator Interconnection Procedures (GIP) except for those submitted under the 10 kW Inverter Process contained in SGIP Attachment 5.
- 1.2 This Agreement governs the terms and conditions under which the Interconnection Customer's Small Generating Facility will interconnect with, and operate in parallel with, the Distribution Provider's Distribution System.
- 1.3 This Agreement does not constitute an agreement to purchase or deliver the Interconnection Customer's power. The purchase or delivery of power and other services that the Interconnection Customer may require will be covered under separate agreements. The Interconnection Customer will be responsible for separately making all necessary arrangements (including scheduling) for delivery of electricity.
- 1.4 Nothing in this Agreement is intended to affect any other agreement between the Distribution Provider and the Interconnection Customer.
- 1.5 Responsibilities of the Parties
 - 1.5.1 The Parties shall perform all obligations of this Agreement in accordance with all Applicable Laws and Regulations, Operating Requirements, and Good Utility Practice.

- 1.5.2 The Interconnection Customer shall construct, interconnect, operate and maintain its Small Generating Facility and construct, operate, and maintain its Interconnection Facilities in accordance with the applicable manufacturer's recommended maintenance schedule, in accordance with this Agreement, and with Good Utility Practice.
- 1.5.3 The Distribution Provider shall construct, operate, and maintain its Distribution System, Transmission System and Interconnection Facilities in accordance with this Agreement, and with Good Utility Practice.
- 1.5.4 The Interconnection Customer agrees to construct its facilities or systems in accordance with applicable specifications that meet or exceed those provided by the National Electrical Safety Code, the American National Standards Institute, IEEE, Underwriter's Laboratory, and Operating Requirements in effect at the time of construction and other applicable national and state codes and standards. The Interconnection Customer agrees to design, install, maintain, and operate its Small Generating Facility so as to reasonably minimize the likelihood of a disturbance adversely affecting or impairing the system or equipment of the Distribution Provider or Affected Systems. The Interconnection Customer shall comply with the Distribution Provider's Interconnection Handbook. In the event of a conflict between the terms of this SGIA and the terms of the Distribution Provider's Interconnection Handbook, the terms in this SGIA shall govern.
- 1.5.5 Each Party shall operate, maintain, repair, and inspect, and shall be fully responsible for the facilities that it now or subsequently may own unless otherwise specified in the Attachments to this Agreement. Each Party shall be responsible for the safe installation, maintenance, repair and condition of their respective lines and appurtenances on their respective sides of the point of change of ownership. The Distribution Provider and the Interconnection Customer, as appropriate, shall provide Interconnection Facilities that adequately protect the Distribution Provider's Distribution and Transmission Systems, personnel, and other persons from damage and injury. The allocation of responsibility for the design, installation, operation, maintenance and ownership of Interconnection Facilities shall be delineated in the Attachments to this Agreement.
- 1.5.6 The Distribution Provider shall coordinate with all Affected Systems to support the interconnection.
- 1.5.7 The Interconnection Customer shall ensure "frequency ride through" capability and "voltage ride through" capability of its Small Generating Facility in accordance with the standards and requirements described in the PG&E Transmission Interconnection Handbook (TIH) and the Distribution Interconnection Handbook (DIH). The Interconnection Customer shall enable these capabilities such that its Small Generating Facility shall not disconnect automatically or instantaneously from the system or equipment of the Distribution Provider and any Affected Systems for a defined under-frequency or over-frequency condition, or an under-voltage or over-voltage condition, as tested pursuant to Article 2.1 of this Agreement. The defined conditions shall be in accordance with Good Utility Practice and consistent with any standards and guidelines that are applied to other generating facilities in the Balancing Authority Area on a

comparable basis. The Small Generating Facility's protective equipment settings shall comply with the Distribution Provider's automatic load-shed program. The Distribution Provider shall review the protective equipment settings to confirm compliance with the automatic load-shed program. The term "ride through" as used herein shall mean the ability of a Small Generating Facility to stay connected to and synchronized with the system or equipment of the Distribution Provider and any Affected Systems during system disturbances within a range of conditions, in accordance with Good Utility Practice and consistent with any standards and guidelines that are applied to other generating facilities in the Balancing Authority on a comparable basis. The term "frequency ride through" as used herein shall mean the ability of a Small Generating Facility to stay connected to and synchronized with the system or equipment of the Distribution Provider and any Affected Systems during system disturbances within a range of under-frequency and over-frequency conditions, in accordance with Good Utility Practice and consistent with any standards and guidelines that are applied to other generating facilities in the Balancing Authority Area on a comparable basis. The term "voltage ride through" as used herein shall mean the ability of a Small Generating Facility to stay connected to and synchronized with the system or equipment of the Distribution Provider and any Affected Systems during system disturbances within a range of under-voltage and over-voltage conditions, in accordance with Good Utility Practice and consistent with any standards and guidelines that are applied to other generating facilities in the Balancing Authority Area on a comparable basis.

1.6 Parallel Operation Obligations

Once the Small Generating Facility has been authorized by the Distribution Provider to commence parallel operation, the Interconnection Customer shall abide by all rules and procedures pertaining to the parallel operation of the Small Generating Facility in the applicable control area, including, but not limited to; 1) the rules and procedures concerning the operation of generation set forth in the Tariff or by the applicable system operator(s) for the Distribution Provider's Distribution and Transmission Systems and; 2) the Operating Requirements set forth in Attachment 5 of this Agreement.

1.7 Metering

The Interconnection Customer shall be responsible for the Distribution Provider's reasonable and necessary cost for the purchase, installation, operation, maintenance, testing, repair, and replacement of metering and data acquisition equipment specified in Attachments 2 and 3 of this Agreement. The Interconnection Customer's metering (and data acquisition, as required) equipment shall conform to applicable industry rules and Operating Requirements.

1.8 Reactive Power

1.8.1 Power Factor Design Criteria

1.8.1.1 Synchronous Generation The Interconnection Customer shall design its Small Generating Facility to maintain a composite power delivery at continuous rated power output at the Point of Interconnection at a power factor within the range of 0.95 leading to 0.95 lagging, unless the Distribution Provider has established different requirements that apply to all similarly situated synchronous generators in the control area on a comparable basis.

- 1.8.1.2 Non-Synchronous Generation The Interconnection Customer shall design its Small Generating Facility to maintain a composite power delivery at continuous rated power output at the high-side of the generator substation at a power factor within the range of 0.95 leading to 0.95 lagging, unless the Distribution Provider has established a different power factor range that applies to all similarly situated non-synchronous generators in the control area on a comparable basis. This power factor range standard shall be dynamic and can be met using, for example, power electronics designed to supply this level of reactive capability (taking into account any limitations due to voltage level, real power output, etc.) or fixed and switched capacitors, or a combination of the two. This requirement shall only apply to newly interconnecting nonsynchronous generators that have not yet executed a Facilities Study Agreement as of the effective date of the Final Rule establishing this requirement (Order No. 827).
- 1.8.2 This Section deleted in FERC Docket No. ER13-494-000
- 1.8.3 This Section deleted in FERC Docket No. ER13-494-000
- 1.8.4 Primary Frequency Response Interconnection Customer shall ensure the primary frequency response capability of its Small Generating Facility by installing, maintaining, and operating a functioning governor or equivalent controls. The term “functioning governor or equivalent controls” as used herein shall mean the required hardware and/or software that provides frequency responsive real power control with the ability to sense changes in system frequency and autonomously adjust the Small Generating Facility’s real power output in accordance with the droop and deadband parameters and in the direction needed to correct frequency deviations. Interconnection Customer is required to install a governor or equivalent controls with the capability of operating: (1) with a maximum 5 percent droop and ± 0.036 Hz deadband; or (2) in accordance with the relevant droop, deadband, and timely and sustained response settings from an approved NERC Reliability Standard providing for equivalent or more stringent parameters. The droop characteristic shall be: (1) based on the nameplate capacity of the Small Generating Facility, and shall be linear in the range of frequencies between 59 to 61 Hz that are outside of the deadband parameter; or (2) based on an approved NERC Reliability Standard providing for an equivalent or more stringent parameter. The deadband parameter shall be: the range of frequencies above and below nominal (60 Hz) in which the governor or equivalent controls is not expected to adjust the Small Generating Facility’s real power output in response to frequency deviations. The deadband shall be implemented: (1) without a step to the droop curve, that is, once the frequency deviation exceeds the deadband parameter, the expected change in the Small Generating Facility’s real power output in response to frequency deviations shall start from zero and then increase (for under-frequency deviations) or decrease (for over-frequency deviations) linearly in proportion to the magnitude of the frequency deviation; or (2) in accordance with an approved NERC Reliability Standard providing for an equivalent or more stringent parameter. Interconnection Customer shall notify Transmission Provider that the primary frequency response capability of the Small Generating Facility has been tested and confirmed during commissioning. Once Interconnection Customer has

synchronized the Small Generating Facility with the Transmission System, Interconnection Customer shall operate the Small Generating Facility consistent with the provisions specified in Sections 1.8.4.1 and 1.8.4.2 of this Agreement. The primary frequency response requirements contained herein shall apply to both synchronous and non-synchronous Small Generating Facilities.

1.8.4.1 Governor or Equivalent Controls. Whenever the Small Generating Facility is operated in parallel with the Transmission System, Interconnection Customer shall operate the Small Generating Facility with its governor or equivalent controls in service and responsive to frequency. Interconnection Customer shall: (1) in coordination with Transmission Provider and/or the relevant balancing authority, set the deadband parameter to: (1) a maximum of ± 0.036 Hz and set the droop parameter to a maximum of 5 percent; or (2) implement the relevant droop and deadband settings from an approved NERC Reliability Standard that provides for equivalent or more stringent parameters. Interconnection Customer shall be required to provide the status and settings of the governor or equivalent controls to Transmission Provider and/or the relevant balancing authority upon request. If Interconnection Customer needs to operate the Small Generating Facility with its governor or equivalent controls not in service, Interconnection Customer shall immediately notify Transmission Provider and the relevant balancing authority, and provide both with the following information: (1) the operating status of the governor or equivalent controls (i.e., whether it is currently out of service or when it will be taken out of service); (2) the reasons for removing the governor or equivalent controls from service; and (3) a reasonable estimate of when the governor or equivalent controls will be returned to service. Interconnection Customer shall make Reasonable Efforts to return its governor or equivalent controls into service as soon as practicable. Interconnection Customer shall make Reasonable Efforts to keep outages of the Small Generating Facility's governor or equivalent controls to a minimum whenever the Small Generating Facility is operated in parallel with the Transmission System.

1.8.4.2 Timely and Sustained Response. Interconnection Customer shall ensure that the Small Generating Facility's real power response to sustained frequency deviations outside of the deadband setting is automatically provided and shall begin immediately after frequency deviates outside of the deadband, and to the extent the Small Generating Facility has operating capability in the direction needed to correct the frequency deviation. Interconnection Customer shall not block or otherwise inhibit the ability of the governor or equivalent controls to respond and shall ensure that the response is not inhibited, except under certain operational constraints including, but not limited to, ambient temperature limitations, physical energy limitations, outages of mechanical equipment, or regulatory requirements. The Small Generating Facility shall sustain the real power response at least until system frequency returns to a value within the deadband setting of the governor or equivalent controls. A Commission-approved Reliability

Standard with equivalent or more stringent requirements shall supersede the above requirements.

- 1.8.4.3 Exemptions. Small Generating Facilities that are regulated by the United States Nuclear Regulatory Commission shall be exempt from Sections 1.8.4, 1.8.4.1, and 1.8.4.2 of this Agreement. Small Generating Facilities that are behind the meter generation that is sized-to-load (i.e., the thermal load and the generation are near-balanced in real-time operation and the generation is primarily controlled to maintain the unique thermal, chemical, or mechanical output necessary for the operating requirements of its host facility) shall be required to install primary frequency response capability in accordance with the droop and deadband capability requirements specified in Section 1.8.4, but shall be otherwise exempt from the operating requirements in Sections 1.8.4, 1.8.4.1, 1.8.4.2, and 1.8.4.4 of this Agreement.
- 1.8.4.4 Electric Storage Resources. Interconnection Customer interconnecting an electric storage resource shall establish an operating range in Attachment 5 of its SGIA that specifies a minimum state of charge and a maximum state of charge between which the electric storage resource will be required to provide primary frequency response consistent with the conditions set forth in Sections 1.8.4, 1.8.4.1, 1.8.4.2 and 1.8.4.3 of this Agreement. Attachment 5 shall specify whether the operating range is static or dynamic, and shall consider: (1) the expected magnitude of frequency deviations in the interconnection; (2) the expected duration that system frequency will remain outside of the deadband parameter in the interconnection; (3) the expected incidence of frequency deviations outside of the deadband parameter in the interconnection; (4) the physical capabilities of the electric storage resource; (5) operational limitations of the electric storage resource due to manufacturer specifications; and (6) any other relevant factors agreed to by Transmission Provider and Interconnection Customer, and in consultation with the relevant transmission owner or balancing authority as appropriate. If the operating range is dynamic, then Attachment 5 must establish how frequently the operating range will be reevaluated and the factors that may be considered during its reevaluation.

Interconnection Customer's electric storage resource is required to provide timely and sustained primary frequency response consistent with Section 1.8.4.2 of this Agreement when it is online and dispatched to inject electricity to the Transmission System and/or receive electricity from the Transmission System. This excludes circumstances when the electric storage resource is not dispatched to inject electricity to the Transmission System and/or dispatched to receive electricity from the Transmission System. If Interconnection Customer's electric storage resource is charging at the time of a frequency deviation outside of its deadband parameter, it is to increase (for over-frequency deviations) or decrease (for under-frequency deviations) the rate at which it is charging in accordance with its droop parameter. Interconnection Customer's electric storage resource is not required to change from charging to discharging, or vice versa, unless the response

necessitated by the droop and deadband settings requires it to do so and it is technically capable of making such a transition.

- 1.9 Capitalized terms used herein shall have the meanings specified in the Glossary of Terms in Attachment 1 or the body of this Agreement.

Article 2. Inspection, Testing, Authorization, and Right of Access

2.1 Equipment Testing and Inspection

2.1.1 The Interconnection Customer shall test and inspect its Small Generating Facility and Interconnection Facilities prior to interconnection. The Interconnection Customer shall notify the Distribution Provider of such activities no fewer than five Business Days (or as may be agreed to by the Parties) prior to such testing and inspection. Testing and inspection shall occur on a Business Day. The Distribution Provider may, at its own expense, send qualified personnel to the Small Generating Facility site to inspect the interconnection and observe the testing. The Interconnection Customer shall provide the Distribution Provider a written test report when such testing and inspection is completed.

2.1.2 The Distribution Provider shall provide the Interconnection Customer written acknowledgment that it has received the Interconnection Customer's written test report. Such written acknowledgment shall not be deemed to be or construed as any representation, assurance, guarantee, or warranty by the Distribution Provider of the safety, durability, suitability, or reliability of the Small Generating Facility or any associated control, protective, and safety devices owned or controlled by the Interconnection Customer or the quality of power produced by the Small Generating Facility.

2.2 Authorization Required Prior to Parallel Operation

2.2.1 The Distribution Provider shall use Reasonable Efforts to list applicable parallel operation requirements in Attachment 5 of this Agreement. Additionally, the Distribution Provider shall notify the Interconnection Customer of any changes to these requirements as soon as they are known. The Distribution Provider shall make Reasonable Efforts to cooperate with the Interconnection Customer in meeting requirements necessary for the Interconnection Customer to commence parallel operations by the in-service date.

2.2.2 The Interconnection Customer shall not operate its Small Generating Facility in parallel with the Distribution Provider's Distribution System without prior written authorization of the Distribution Provider. The Distribution Provider will provide such authorization once the Distribution Provider receives notification that the Interconnection Customer has complied with all applicable parallel operation requirements. Such authorization shall not be unreasonably withheld, conditioned, or delayed.

2.3 Right of Access

- 2.3.1 Upon reasonable notice, the Distribution Provider may send a qualified person to the premises of the Interconnection Customer at or immediately before the time the Small Generating Facility first produces energy to inspect the interconnection, and observe the commissioning of the Small Generating Facility (including any required testing), startup, and operation for a period of up to three Business Days after initial start-up of the unit. In addition, the Interconnection Customer shall notify the Distribution Provider at least five Business Days prior to conducting any on-site verification testing of the Small Generating Facility.
- 2.3.2 Following the initial inspection process described above, at reasonable hours, and upon reasonable notice, or at any time without notice in the event of an emergency or hazardous condition, the Distribution Provider shall have access to the Interconnection Customer's premises for any reasonable purpose in connection with the performance of the obligations imposed on it by this Agreement or if necessary to meet its legal obligation to provide service to its customers.
- 2.3.3 Each Party shall be responsible for its own costs associated with following this article.

Article 3. Effective Date, Term, Termination, and Disconnection

3.1 Effective Date

This Agreement shall become effective upon execution by the Parties subject to acceptance by FERC (if applicable), or if filed unexecuted, upon the date specified by the FERC. The Distribution Provider shall promptly file this Agreement with the FERC upon execution, if required.

3.2 Term of Agreement

This Agreement shall become effective on the Effective Date and shall remain in effect for a period of **ten** years from the Effective Date or such other longer period as the Interconnection Customer may request and shall be automatically renewed for each successive one-year period thereafter, unless terminated earlier in accordance with article 3.3 of this Agreement.

3.3 Termination

No termination shall become effective until the Parties have complied with all Applicable Laws and Regulations applicable to such termination, including the filing with FERC of a notice of termination of this Agreement (if required), which notice has been accepted for filing by FERC.

3.3.1 The Interconnection Customer may terminate this Agreement at any time by giving the Distribution Provider 20 Business Days written notice.

3.3.2 Either Party may terminate this Agreement after Default pursuant to article 7.6.

3.3.3 Upon termination of this Agreement, the Small Generating Facility will be disconnected from the Distribution Provider's Distribution System. The termination of this Agreement shall not relieve either Party of its liabilities and obligations, owed or continuing at the time of the termination.

3.3.4 The provisions of this article shall survive termination or expiration of this Agreement.

3.4 Temporary Disconnection

Temporary disconnection shall continue only for so long as reasonably necessary under Good Utility Practice.

3.4.1 Emergency Conditions-- "Emergency Condition" shall mean a condition or situation: (1) that in the judgment of the Party making the claim is imminently likely to endanger life or property; or (2) that, in the case of the Distribution Provider, is imminently likely (as determined in a non-discriminatory manner) to cause a material adverse effect on the security of, or damage to the Distribution System, the Distribution Provider's Interconnection Facilities any Affected Systems; or (3) that, in the case of the Interconnection Customer, is imminently likely (as determined in a non-discriminatory manner) to cause a material adverse effect on the security of, or damage to, the Small Generating Facility or the Interconnection Customer's Interconnection Facilities. Under Emergency Conditions, the Distribution Provider may immediately suspend interconnection service and temporarily disconnect the Small Generating Facility. The Distribution Provider shall notify the Interconnection Customer promptly when it becomes aware of an Emergency Condition that may reasonably be expected to affect the Interconnection Customer's operation of the Small Generating Facility. The Interconnection Customer shall notify the Distribution Provider promptly when it becomes aware of an Emergency Condition that may reasonably be expected to affect the Distribution Provider's Distribution System or other Affected Systems. To the extent information is known, the notification shall describe the Emergency Condition, the extent of the damage or deficiency, the expected effect on the operation of both Parties' facilities and operations, its anticipated duration, and the necessary corrective action.

3.4.2 Routine Maintenance, Construction, and Repair

The Distribution Provider may interrupt interconnection service or curtail the output of the Small Generating Facility and temporarily disconnect the Small Generating Facility from the Distribution Provider's Distribution System when necessary for routine maintenance, construction, and repairs on the Distribution Provider's Distribution System and/or Transmission System. The Distribution Provider shall provide the Interconnection Customer with five Business Days notice prior to such interruption. The Distribution Provider shall use Reasonable Efforts to coordinate such reduction or temporary disconnection with the Interconnection Customer.

3.4.3 Forced Outages

During any forced outage, the Distribution Provider may suspend interconnection service to effect immediate repairs on the Distribution Provider's Distribution System and/or Transmission System. The Distribution Provider shall use Reasonable Efforts to provide the Interconnection Customer with prior notice. If prior notice is not given, the Distribution Provider shall, upon request, provide the Interconnection Customer written documentation after the fact explaining the circumstances of the disconnection.

3.4.4 Adverse Operating Effects

The Distribution Provider shall notify the Interconnection Customer as soon as practicable if, based on Good Utility Practice, operation of the Small Generating Facility may cause disruption or deterioration of service to other customers served from the same electric system, or if operating the Small Generating Facility could cause damage to the Distribution Provider's Distribution System or Affected Systems. Supporting documentation used to reach the decision to disconnect shall be provided to the Interconnection Customer upon request. If, after notice, the Interconnection Customer fails to remedy the adverse operating effect within a reasonable time, the Distribution Provider may disconnect the Small Generating Facility. The Distribution Provider shall provide the Interconnection Customer with five Business Day notice of such disconnection, unless the provisions of article 3.4.1 apply.

3.4.5 Modification of the Small Generating Facility

The Interconnection Customer must receive written authorization from the Distribution Provider before making any change to the Small Generating Facility that may have a material impact on the safety or reliability of the Distribution System and/or Transmission System. Such authorization shall not be unreasonably withheld. Modifications shall be done in accordance with Good Utility Practice. If the Interconnection Customer makes such modification without the Distribution Provider's prior written authorization, the latter shall have the right to temporarily disconnect the Small Generating Facility.

3.4.6 Reconnection

The Parties shall cooperate with each other to restore the Small Generating Facility, Interconnection Facilities, and/or the Distribution Provider's Distribution System or Transmission System to their normal operating state as soon as reasonably practicable following a temporary disconnection.

Article 4. Cost Responsibility for Interconnection Facilities and Distribution Upgrades

4.1 Interconnection Facilities

4.1.1 The Interconnection Customer shall pay for the cost of the Interconnection Facilities itemized in Attachment 2 of this Agreement. The Distribution Provider shall provide a best estimate cost, including overheads, for the purchase and construction of its Interconnection Facilities and provide a detailed itemization of such costs. Costs associated with Interconnection Facilities may be shared with other entities that may benefit from such facilities by agreement of the Interconnection Customer, such other entities, and the Distribution Provider.

4.1.2 The Interconnection Customer shall be responsible for its share of all reasonable expenses, including overheads, associated with (1) owning, operating, maintaining, repairing, and replacing its own Interconnection Facilities, and (2) operating, maintaining, repairing, and replacing the Distribution Provider's Interconnection Facilities.

4.2 Distribution Upgrades

The Distribution Provider shall design, procure, construct, install, and own the

Distribution Upgrades described in Attachment 6 of this Agreement. If the Distribution Provider and the Interconnection Customer agree, the Interconnection Customer may construct Distribution Upgrades that are located on land owned by the Interconnection Customer. The actual cost of the Distribution Upgrades, including overheads, as well as costs associated with operating, maintaining, repairing, and replacing Distribution Provider's Distribution Upgrades shall be directly assigned to the Interconnection Customer.

Article 5. Cost Responsibility for Network Upgrades

5.1 Applicability

No portion of this Article 5 shall apply unless the interconnection of the Small Generating Facility requires Network Upgrades.

5.2 Network Upgrades

The Distribution Provider or the Transmission Owner shall design, procure, construct, install, and own the Network Upgrades described in Attachment 6 of this Agreement. If the Distribution Provider and the Interconnection Customer agree, the Interconnection Customer may construct Network Upgrades that are located on land owned by the Interconnection Customer. Unless the Distribution Provider elects to pay for Network Upgrades, the actual cost of the Network Upgrades, including overheads, shall be borne by the Interconnection Customer unless Article 5.2.1 directs otherwise.

5.2.1 Repayment of Amounts Advanced for Network Upgrades

To the extent the CAISO Tariff, Section 12.3.2 of Appendix Y and Section 14.3.2 of Appendix DD, and successor tariffs provides for cash repayment or Congestion Revenue Rights to the Interconnection Customer for contribution to the cost of Network Upgrades, the Interconnection Customer shall be entitled to a cash repayment of Congestion Revenue Rights, equal to the total amount paid to the Distribution Provider and Affected System operator, if any, for Network Upgrades, including any tax gross-up or other tax-related payments associated with the Network Upgrades, and not otherwise refunded to the Interconnection Customer.

Any repayment shall include interest calculated in accordance with the methodology set forth in FERC's regulations at 18 C.F.R. 35.19a(a)(2)(iii) from the date of any payment for Network Upgrades through the date on which the Interconnection Customer receives a repayment of such payment pursuant to this subparagraph. The Interconnection Customer may assign such repayment rights to any person.

5.2.1.1 If the Interconnection Customer is entitled to a cash repayment pursuant to Article 5.2.1, the Interconnection Customer, the Distribution Provider, and Affected System operator may adopt any alternative payment schedule that is mutually agreeable so long as the Distribution Provider and Affected System operator take one of the following actions no later than five years from the Commercial Operation Date: (1) return to the Interconnection Customer any amounts advanced for Network Upgrades not previously repaid, or (2) declare in writing that the Distribution Provider or Affected System operator(s) will continue to

provide payments to the Interconnection Customer on a dollar-for-dollar basis for the non-usage sensitive portion of transmission charges, or develop an alternative schedule that is mutually agreeable and provides for the return of all amounts advanced for Network Upgrades not previously repaid; however, full reimbursement shall not extend beyond twenty (20) years from the commercial operation date.

5.2.1.2 If the Small Generating Facility fails to achieve commercial operation, but it or another generating facility is later constructed and requires use of the Network Upgrades, the Distribution Provider and Affected System operator shall at that time reimburse the Interconnection Customer for the amounts advanced for the Network Upgrades if the Interconnection Customer is entitled to a cash repayment pursuant to Article 5.2.1. Before any such reimbursement can occur, the Interconnection Customer, or the entity that ultimately constructs the generating facility, if different, is responsible for identifying the entity to which reimbursement must be made.

5.3 Special Provisions for Affected Systems

Unless the Distribution Provider provides, under this Agreement, for the repayment of amounts advanced to Affected System operator(s) for Network Upgrades, the Interconnection Customer and Affected System operator shall enter into an agreement that provides for such repayment. The agreement shall specify the terms governing payments to be made by the Interconnection Customer to Affected System operator as well as the repayment by Affected System operator.

5.4 Rights Under Other Agreements

Notwithstanding any other provision of this Agreement, nothing herein shall be construed as relinquishing or foreclosing any rights, including but not limited to firm transmission rights, capacity rights, transmission congestion rights, or transmission credits, that the Interconnection Customer shall be entitled to, now or in the future, under any other agreement or tariff as a result of, or otherwise associated with, the transmission capacity, if any, created by the Network Upgrades, including the right to obtain cash reimbursements or transmission credits for transmission service that is not associated with the Small Generating Facility.

Article 6. Billing, Payment, Milestones, and Financial Security

6.1 Billing and Payment Procedures and Final Accounting

6.1.1 The Distribution Provider shall bill the Interconnection Customer for the design, engineering, construction, and procurement costs of Interconnection Facilities and Upgrades contemplated by this Agreement on a monthly basis, or as otherwise agreed by the Parties. The Interconnection Customer shall pay each bill within 30 calendar days of receipt, or as otherwise agreed to by the Parties.

6.1.2 Within six months of completing the construction and installation of the Distribution Provider's Interconnection Facilities and/or Upgrades described in the Attachments to this Agreement, the Distribution Provider shall provide the Interconnection Customer with a final accounting report of any difference

between (1) the Interconnection Customer's cost responsibility for the actual cost of such facilities or Upgrades, and (2) the Interconnection Customer's previous aggregate payments to the Distribution Provider for such facilities or Upgrades. If the Interconnection Customer's cost responsibility exceeds its previous aggregate payments, the Distribution Provider shall invoice the Interconnection Customer for the amount due and the Interconnection Customer shall make payment to the Distribution Provider within 30 calendar days. If the Interconnection Customer's previous aggregate payments exceed its cost responsibility under this Agreement, the Distribution Provider shall refund to the Interconnection Customer an amount equal to the difference within 30 calendar days of the final accounting report.

6.2 Milestones

The Parties shall agree on milestones for which each Party is responsible and list them in Attachment 4 of this Agreement. A Party's obligations under this provision may be extended by agreement. If a Party anticipates that it will be unable to meet a milestone for any reason other than an Uncontrollable Force Event, it shall immediately notify the other Party of the reason(s) for not meeting the milestone and (1) propose the earliest reasonable alternate date by which it can attain this and future milestones, and (2) requesting appropriate amendments to Attachment 4. The Party affected by the failure to meet a milestone shall not unreasonably withhold agreement to such an amendment unless (1) it will suffer significant uncompensated economic or operational harm from the delay, (2) attainment of the same milestone has previously been delayed, or (3) it has reason to believe that the delay in meeting the milestone is intentional or unwarranted notwithstanding the circumstances explained by the Party proposing the amendment.

6.3 Financial Security Arrangements

The Interconnection Customer shall provide the Distribution Provider an Interconnection Financial Security by the earliest date of either (i) no later than the financial security posting milestone date negotiated in Attachment 4 of this Agreement, (ii) no later than 180 Calendar Days after the effective date of this agreement, or (iii) at least twenty (20) Business Days prior to the commencement of the design, procurement, installation, or construction of a discrete portion of the Distribution Provider's Interconnection Facilities and Upgrades. The Interconnection Customer shall provide the Distribution Provider, at the Interconnection Customer's option, a guarantee, letter of credit, escrow agreement or other form of security that is reasonably acceptable to the Distribution Provider and is consistent with the Uniform Commercial Code of the jurisdiction where the Point of Interconnection is located. Such security for payment shall be in an amount sufficient to cover the costs for constructing, designing, procuring, and installing the applicable portion of the Distribution Provider's Interconnection Facilities and Upgrades and shall be reduced on a dollar-for-dollar basis for payments made to the Distribution Provider under this Agreement during its term. In addition:

6.3.1 The guarantee must be made by an entity that meets the creditworthiness requirements of the Distribution Provider, and contain terms and conditions that guarantee payment of any amount that may be due from the Interconnection Customer, up to an agreed-to maximum amount.

6.3.2 The letter of credit or escrow agreement must be issued by a financial institution or insured reasonably acceptable to the Distribution Provider and must specify a reasonable expiration date.

6.4 Responsibility for any Outstanding Interconnection Study Costs

The Interconnection Customer must complete payment on all outstanding invoiced interconnection study costs no later than the financial security posting milestone date negotiated in Attachment 4 of this Agreement. Study costs not yet invoiced within thirty (30) Calendar Days of that financial security posting deadline must be paid by the Interconnection Customer within thirty (30) Calendar Days of the date of the invoice once they are invoiced to the Interconnection Customer.

Failure to complete payment on these interconnection study invoices by these deadlines will constitute Default on this Agreement by the Interconnection Customer, subject to the terms of Article 7.6 "Default".

Article 7. Assignment, Liability, Indemnity, Uncontrollable Force, Consequential Damages, and Default

7.1 Assignment

This Agreement may be assigned by either Party upon fifteen (15) Business Days prior written notice and opportunity to object by the other Party; provided that:

- 7.1.1 Either Party may assign this Agreement without the consent of the other Party to any affiliate of the assigning Party with an equal or greater credit rating and with the legal authority and operational ability to satisfy the obligations of the assigning Party under this Agreement;
- 7.1.2 The Interconnection Customer shall have the right to assign this Agreement, without the consent of the Distribution Provider, for collateral security purposes to aid in providing financing for the Small Generating Facility, provided that the Interconnection Customer will promptly notify the Distribution Provider of any such assignment.
- 7.1.3 Any attempted assignment that violates this article is void and ineffective. Assignment shall not relieve a Party of its obligations, nor shall a Party's obligations be enlarged, in whole or in part, by reason thereof. An assignee is responsible for meeting the same financial, credit, and insurance obligations as the Interconnection Customer. Where required, consent to assignment will not be unreasonably withheld, conditioned or delayed.

7.2 Limitation of Liability

Each Party's liability to the other Party for any loss, cost, claim, injury, liability, or expense, including reasonable attorney's fees, relating to or arising from any act or omission in its performance of this Agreement, shall be limited to the amount of direct damage actually incurred. In no event shall either Party be liable to the other Party for any indirect, special, consequential, or punitive damages, except as authorized by this Agreement.

7.3 Indemnity

- 7.3.1 This provision protects each Party from liability incurred to third parties as a result of carrying out the provisions of this Agreement. Liability under this provision is exempt from the general limitations on liability found in article 7.2.
- 7.3.2 The Parties shall at all times indemnify, defend, and hold the other Party harmless from, any and all damages, losses, claims, including claims and actions relating to injury to or death of any person or damage to property, demand, suits, recoveries, costs and expenses, court costs, attorney fees, and all other obligations by or to third parties, arising out of or resulting from the other Party's action or failure to meet its obligations under this Agreement on behalf of the indemnifying Party, except in cases of gross negligence or intentional wrongdoing by the indemnified Party.
- 7.3.3 If an indemnified person is entitled to indemnification under this article as a result of a claim by a third party, and the indemnifying Party fails, after notice and reasonable opportunity to proceed under this article, to assume the defense of such claim, such indemnified person may at the expense of the indemnifying Party contest, settle or consent to the entry of any judgment with respect to, or pay in full, such claim.
- 7.3.4 If an indemnifying party is obligated to indemnify and hold any indemnified person harmless under this article, the amount owing to the indemnified person shall be the amount of such indemnified person's actual loss, net of any insurance or other recovery.
- 7.3.5 Promptly after receipt by an indemnified person of any claim or notice of the commencement of any action or administrative or legal proceeding or investigation as to which the indemnity provided for in this article may apply, the indemnified person shall notify the indemnifying party of such fact. Any failure of or delay in such notification shall not affect a Party's indemnification obligation unless such failure or delay is materially prejudicial to the indemnifying party.
- 7.4 Consequential Damages
Other than as expressly provided for in this Agreement, neither Party shall be liable under any provision of this Agreement for any losses, damages, costs or expenses for any special, indirect, incidental, consequential, or punitive damages, including but not limited to loss of profit or revenue, loss of the use of equipment, cost of capital, cost of temporary equipment or services, whether based in whole or in part in contract, in tort, including negligence, strict liability, or any other theory of liability; provided, however, that damages for which a Party may be liable to the other Party under another agreement will not be considered to be special, indirect, incidental, or consequential damages hereunder.
- 7.5 Uncontrollable Force
- 7.5.1 As used in this article, an Uncontrollable Force shall mean "any act of God, labor disturbance, act of the public enemy, war, insurrection, riot, fire, storm, flood, earthquake, explosion, breakage or accident to machinery or equipment, any curtailment, order, regulation or restriction imposed by governmental, military or lawfully established civilian authorities, or any other cause beyond the reasonable control of the Distribution Provider or Interconnection Customer

which could not be avoided through the exercise of Good Utility Practice. An Uncontrollable Force Event does not include an act of negligence or intentional wrongdoing by the Party claiming Uncontrollable Force."

7.5.2 If an Uncontrollable Force Event prevents a Party from fulfilling any obligations under this Agreement, the Party affected by the Uncontrollable Force Event (Affected Party) shall promptly notify the other Party, either in writing or via the telephone, of the existence of the Uncontrollable Force Event. The notification must specify in reasonable detail the circumstances of the Uncontrollable Force Event, its expected duration, and the steps that the Affected Party is taking to mitigate the effects of the event on its performance. The Affected Party shall keep the other Party informed on a continuing basis of developments relating to the Uncontrollable Force Event until the event ends. The Affected Party will be entitled to suspend or modify its performance of obligations under this Agreement (other than the obligation to make payments) only to the extent that the effect of the Uncontrollable Force Event cannot be mitigated by the use of Reasonable Efforts. The Affected Party will use Reasonable Efforts to resume its performance as soon as possible.

7.6 Default

7.6.1 No Default shall exist where such failure to discharge an obligation (other than the payment of money) is the result of an Uncontrollable Force Event as defined in this Agreement or the result of an act or omission of the other Party. Upon a Default, the non-defaulting Party shall give written notice of such Default to the defaulting Party. Except as provided in article 7.6.2, the defaulting Party shall have 60 calendar days from receipt of the Default notice within which to cure such Default; provided however, if such Default is not capable of cure within 60 calendar days, the defaulting Party shall commence such cure within 20 calendar days after notice and continuously and diligently complete such cure within six months from receipt of the Default notice; and, if cured within such time, the Default specified in such notice shall cease to exist.

7.6.2 If a Default is not cured as provided in this article, or if a Default is not capable of being cured within the period provided for herein, the non-defaulting Party shall have the right to terminate this Agreement by written notice at any time until cure occurs, and be relieved of any further obligation hereunder and, whether or not that Party terminates this Agreement, to recover from the defaulting Party all amounts due hereunder, plus all other damages and remedies to which it is entitled at law or in equity. The provisions of this article will survive termination of this Agreement.

Article 8. Insurance

8.1 The Interconnection Customer shall, at its own expense, maintain in force general liability insurance without any exclusion for liabilities related to the interconnection undertaken pursuant to this Agreement. The amount of such insurance shall be sufficient to insure against all reasonably foreseeable direct liabilities given the size and nature of the generating equipment being interconnected, the interconnection itself, and the characteristics of the system to which the interconnection is made. The Interconnection

Customer shall obtain additional insurance only if necessary as a function of owning and operating a generating facility. Such insurance shall be obtained from an insurance provider authorized to do business in the State where the interconnection is located. Certification that such insurance is in effect shall be provided upon request of the Distribution Provider, except that the Interconnection Customer shall show proof of insurance to the Distribution Provider no later than ten Business Days prior to the anticipated commercial operation date. An Interconnection Customer of sufficient credit-worthiness may propose to self-insure for such liabilities, and such a proposal shall not be unreasonably rejected.

- 8.2 The Distribution Provider agrees to maintain general liability insurance or self-insurance consistent with the Distribution Provider's commercial practice. Such insurance or self-insurance shall not exclude coverage for the Distribution Provider's liabilities undertaken pursuant to this Agreement.
- 8.3 The Parties further agree to notify each other whenever an accident or incident occurs resulting in any injuries or damages that are included within the scope of coverage of such insurance, whether or not such coverage is sought.

Article 9. Confidentiality

- 9.1 Confidential Information shall mean any confidential and/or proprietary information provided by one Party to the other Party that is clearly marked or otherwise designated "Confidential." For purposes of this Agreement all design, operating specifications, and metering data provided by the Interconnection Customer shall be deemed Confidential Information regardless of whether it is clearly marked or otherwise designated as such.
- 9.2 Confidential Information does not include information previously in the public domain, required to be publicly submitted or divulged by Governmental Authorities (after notice to the other Party and after exhausting any opportunity to oppose such publication or release), or necessary to be divulged in an action to enforce this Agreement. Each Party receiving Confidential Information shall hold such information in confidence and shall not disclose it to any third party nor to the public without the prior written authorization from the Party providing that information, except to fulfill obligations under this Agreement, or to fulfill legal or regulatory requirements.
 - 9.2.1 Each Party shall employ at least the same standard of care to protect Confidential Information obtained from the other Party as it employs to protect its own Confidential Information.
 - 9.2.2 Each Party is entitled to equitable relief, by injunction or otherwise, to enforce its rights under this provision to prevent the release of Confidential Information without bond or proof of damages, and may seek other remedies available at law or in equity for breach of this provision.
- 9.3 Notwithstanding anything in this article to the contrary, and pursuant to 18 CFR § 1 b.20, if FERC, during the course of an investigation or otherwise, requests information from one of the Parties that is otherwise required to be maintained in confidence pursuant to this Agreement, the Party shall provide the requested information to FERC, within the time provided for in the request for information. In providing the information to FERC, the

Party may, consistent with 18 CFR § 388.112, request that the information be treated as confidential and non-public by FERC and that the information be withheld from public disclosure. Parties are prohibited from notifying the other Party to this Agreement prior to the release of the Confidential Information to FERC. The Party shall notify the other Party to this Agreement when it is notified by FERC that a request to release Confidential Information has been received by FERC, at which time either of the Parties may respond before such information would be made public, pursuant to 18 CFR § 388.112. Requests from a state regulatory body conducting a confidential investigation shall be treated in a similar manner if consistent with the applicable state rules and regulations.

Article 10. Disputes

- 10.1 The Parties agree to attempt to resolve all disputes arising out of the interconnection process according to the provisions of this article.
- 10.2 In the event of a dispute, either Party shall provide the other Party with a written Notice of Dispute. Such Notice shall describe in detail the nature of the dispute.
- 10.3 If the dispute has not been resolved within two Business Days after receipt of the Notice, either Party may contact FERC's Dispute Resolution Service (DRS) for assistance in resolving the dispute.
- 10.4 The DRS will assist the Parties in either resolving their dispute or in selecting an appropriate dispute resolution venue (e.g., mediation, settlement judge, early neutral evaluation, or technical expert) to assist the Parties in resolving their dispute. DRS can be reached at 1-877-337-2237 or via the internet at <http://www.ferc.gov/legal/adr.asp>.
- 10.5 Each Party agrees to conduct all negotiations in good faith and will be responsible for one-half of any costs paid to neutral third-parties.
- 10.6 If neither Party elects to seek assistance from the DRS, or if the attempted dispute resolution fails, then either Party may exercise whatever rights and remedies it may have in equity or law consistent with the terms of this Agreement.

Article 11. Taxes

- 11.1 The Parties agree to follow all applicable tax laws and regulations, consistent with FERC policy and Internal Revenue Service requirements.
- 11.2 Each Party shall cooperate with the other to maintain the other Party's tax status. Nothing in this Agreement is intended to adversely affect the Distribution Provider's tax exempt status with respect to the issuance of bonds including, but not limited to, local furnishing bonds.

Article 12. Miscellaneous

12.1 Governing Law, Regulatory Authority, and Rules

The validity, interpretation and enforcement of this Agreement and each of its provisions shall be governed by the laws of the state of California (where the Point of Interconnection is located), without regard to its conflicts of law principles. This Agreement is subject to all Applicable Laws and Regulations. Each Party expressly reserves the right to seek changes in, appeal, or otherwise contest any laws, orders, or regulations of a Governmental Authority.

12.2 Amendment

The Parties may amend this Agreement by a written instrument duly executed by both Parties.

12.3 No Third-Party Beneficiaries

This Agreement is not intended to and does not create rights, remedies, or benefits of any character whatsoever in favor of any persons, corporations, associations, or entities other than the Parties, and the obligations herein assumed are solely for the use and benefit of the Parties, their successors in interest and where permitted, their assigns.

12.4 Waiver

12.4.1 The failure of a Party to this Agreement to insist, on any occasion, upon strict performance of any provision of this Agreement will not be considered a waiver of any obligation, right, or duty of, or imposed upon, such Party.

12.4.2 Any waiver at any time by either Party of its rights with respect to this Agreement shall not be deemed a continuing waiver or a waiver with respect to any other failure to comply with any other obligation, right, duty of this Agreement. Termination or default of this Agreement for any reason by Interconnection Customer shall not constitute a waiver of the Interconnection Customer's legal rights to obtain an interconnection from the Distribution Provider. Any waiver of this Agreement shall, if requested, be provided in writing.

12.5 Entire Agreement

This Agreement, including all Attachments, constitutes the entire agreement between the Parties with reference to the subject matter hereof, and supersedes all prior and contemporaneous understandings or agreements, oral or written, between the Parties with respect to the subject matter of this Agreement. There are no other agreements, representations, warranties, or covenants which constitute any part of the consideration for, or any condition to, either Party's compliance with its obligations under this Agreement.

12.6 Multiple Counterparts

This Agreement may be executed in two or more counterparts, each of which is deemed an original but all constitute one and the same instrument.

12.7 No Partnership

This Agreement shall not be interpreted or construed to create an association, joint venture, agency relationship, or partnership between the Parties or to impose any partnership obligation or partnership liability upon either Party. Neither Party shall have any right, power or authority to enter into any agreement or undertaking for, or act on behalf of, or to act as or be an agent or representative of, or to otherwise bind, the other

Party.

12.8 Severability

If any provision or portion of this Agreement shall for any reason be held or adjudged to be invalid or illegal or unenforceable by any court of competent jurisdiction or other Governmental Authority, (1) such portion or provision shall be deemed separate and independent, (2) the Parties shall negotiate in good faith to restore insofar as practicable the benefits to each Party that were affected by such ruling, and (3) the remainder of this Agreement shall remain in full force and effect.

12.9 Security Arrangements

Infrastructure security of electric system equipment and operations and control hardware and software is essential to ensure day-to-day reliability and operational security. FERC expects all transmission providers, market participants, and interconnection customers interconnected to electric systems to comply with the recommendations offered by the President's Critical Infrastructure Protection Board and, eventually, best practice recommendations from the electric reliability authority. All public utilities are expected to meet basic standards for system infrastructure and operational security, including physical, operational, and cyber-security practices.

12.10 Environmental Releases

Each Party shall notify the other Party, first orally and then in writing, of the release of any hazardous substances, any asbestos or lead abatement activities, or any type of remediation activities related to the Small Generating Facility or the Interconnection Facilities, each of which may reasonably be expected to affect the other Party. The notifying Party shall (1) provide the notice as soon as practicable, provided such Party makes a good faith effort to provide the notice no later than 24 hours after such Party becomes aware of the occurrence, and (2) promptly furnish to the other Party copies of any publicly available reports filed with any governmental authorities addressing such events.

12.11 Subcontractors

Nothing in this Agreement shall prevent a Party from utilizing the services of any subcontractor as it deems appropriate to perform its obligations under this Agreement; provided, however, that each Party shall require its subcontractors to comply with all applicable terms and conditions of this Agreement in providing such services and each Party shall remain primarily liable to the other Party for the performance of such subcontractor.

12.11.1 The creation of any subcontract relationship shall not relieve the hiring Party of any of its obligations under this Agreement. The hiring Party shall be fully responsible to the other Party for the acts or omissions of any subcontractor the hiring Party hires as if no subcontract had been made; provided, however, that in no event shall the Distribution Provider be liable for the actions or inactions of the Interconnection Customer or its subcontractors with respect to obligations of the Interconnection Customer under this Agreement. Any applicable obligation imposed by this Agreement upon the hiring Party shall be equally binding upon, and shall be construed as having application to, any subcontractor of such Party.

12.11.2 The obligations under this article will not be limited in any way by any limitation of subcontractor's insurance.

12.12 Reservation of Rights

The Distribution Provider shall have the right to make a unilateral filing with FERC to modify this Agreement with respect to any rates, terms and conditions, charges, classifications of service, rule or regulation under section 205 or any other applicable provision of the Federal Power Act and FERC's rules and regulations thereunder, and the Interconnection Customer shall have the right to make a unilateral filing with FERC to modify this Agreement under any applicable provision of the Federal Power Act and FERC's rules and regulations; provided that each Party shall have the right to protest any such filing by the other Party and to participate fully in any proceeding before FERC in which such modifications may be considered. Nothing in this Agreement shall limit the rights of the Parties or of FERC under sections 205 or 206 of the Federal Power Act and FERC's rules and regulations, except to the extent that the Parties otherwise agree as provided herein.

Article 13. Notices

13.1 General

Unless otherwise provided in this Agreement, any written notice, demand, or request required or authorized in connection with this Agreement ("Notice") shall be deemed properly given if delivered in person, delivered by recognized national courier service, or sent by first class mail, postage prepaid, to the person specified below:

If to the Interconnection Customer:

Central Coast Community Energy
Attention: Dennis Dyc-O'neal
70 Garden Court, Ste 300
Monterey, CA 93940
Phone: (877) 455-2223
Email: ddyconeal@3ce.org

If to the Distribution Provider:

Pacific Gas and Electric Company
Attention: Electric Grid Interconnection - Contract Management
300 Lakeside Drive
Oakland, CA 94612-3534
Email: EGContractMgmt@pge.com

13.2 Billing and Payment

Billings and payments shall be sent to the addresses below:

Interconnection Customer:

Central Coast Community Energy
Attention: Dennis Dyc-O'Neal

70 Garden Court, Ste 300
Monterey, CA 93940
Phone: (877) 455-2223
Email: ddyconeal@3ce.org

Distribution Provider:

Pacific Gas and Electric Company
Attention: Electric Grid Interconnection - Contract Management
300 Lakeside Drive
Oakland, CA 94612-3534
Email: EGIContractMgmt@pge.com

13.3 Alternative Forms of Notice

Any notice or request required or permitted to be given by either Party to the other and not required by this Agreement to be given in writing may be so given by telephone, facsimile or e-mail to the telephone numbers and e-mail addresses set out below:

If to the Interconnection Customer:

Central Coast Community Energy
Attention: Dennis Dyc-O'neal
70 Garden Court, Ste 300
Monterey, CA 93940
Phone: (877) 455-2223
Email: ddyconeal@3ce.org

If to the Distribution Provider:

Pacific Gas and Electric Company
Attention: Electric Grid Interconnection - Contract Management
300 Lakeside Drive
Oakland, CA 94612-3534
Email: EGIContractMgmt@pge.com

13.4 Designated Operating Representative

The Parties may also designate operating representatives to conduct the communications which may be necessary or convenient for the administration of this Agreement. This person will also serve as the point of contact with respect to operations and maintenance of the Party's facilities.

Interconnection Customer's Operating Representative:

Central Coast Community Energy
Attention: Dennis Dyc-O'neal
70 Garden Court, Ste 300
Monterey, CA 93940
Phone: (877) 455-2223
Email: ddyconeal@3ce.org

Distribution Provider's Operating Representative:

Pacific Gas and Electric Company
Concord Distribution Control Center
1020 Detroit Ave., Concord, CA 94518
Email: CentralDCCOperationsEngineers@pge.com

Work Management Desk (Planned Clearance Requests)
Attention: Santa Cruz District (AOR 6- Central Coast Division)
Phone: (844) 743-2100

Real Time Operator Desk (Real Time Operational Issues)
Attention: Santa Cruz District (AOR 6- Central Coast Division)
Phone: (844) 743-3322

13.5 Changes to the Notice Information

Either Party may change this information by giving five Business Days written notice prior to the effective date of the change.

In Process

Article 14. Signatures

IN WITNESS WHEREOF, the Parties have caused this Agreement to be executed by their respective duly authorized representatives.

For the Distribution Provider: **Pacific Gas and Electric Company**

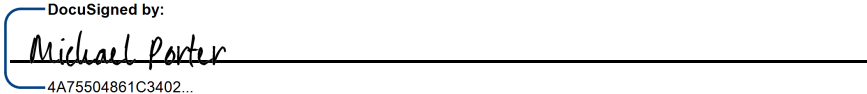
Signature: 
Name: Michael Porter
Title: Manager, EGI Wholesale Operations
Date: 7/20/2023 | 8:48:47 PDT

For the Interconnection Customer: **Central Coast Community Energy**

Signature: 
Name: Robert Shaw
Title: COO
Date: 8/9/2023 | 3:35:34 PDT

Glossary of Terms

Adverse System Impact -- A potential or actual negative effect due to technical or operational limits on conductors or equipment being exceeded that may compromise the safety and reliability of the electric system.

Affected System -- An electric system other than the Distribution Provider's Distribution System that may be affected by the proposed interconnection, including but not limited to the Transmission System.

Affected System Operator -- The entity that operates an Affected System.

Affiliate -- With respect to a corporation, partnership or other entity, each such other corporation, partnership or other entity that directly or indirectly, through one or more intermediaries, controls, is controlled by, or is under common control with, such corporation, partnership or other entity.

Applicable Laws and Regulations -- All duly promulgated applicable federal, state and local laws, regulations, rules, ordinances, codes, decrees, judgments, directives, or judicial or administrative orders, permits and other duly authorized actions of any Governmental Authority.

Applicable Reliability Council -- The reliability council applicable to the Distribution System to which the Generating Facility is directly interconnected.

Applicable Reliability Standards -- The requirements and guidelines of NERC, the Applicable Reliability Council, and the Control Area of the Distribution System to which the Generating Facility is directly interconnected, including the requirements pursuant to Section 215 of the Federal Power Act.

Area Deliverability Constraint -- A transmission system operating limit, that would constrain the deliverability of a substantial number of generators if the CAISO were to assign full capacity or partial capacity deliverability status to additional generating facilities in one or more specified geographic or electrical areas of the CAISO Controlled Grid in a total amount that is greater than the TP Deliverability for those areas. May also be a transmission system operating limit that constrains a quantity of generation in a local area of the grid that is larger than the generation amount identified in the applicable Transmission Planning Process (TPP) portfolio for the entire portfolio area. May also be a transmission system operating limit that constrains all or most of the same generation already constrained by a previously identified Area Deliverability Constraint.

Area Delivery Network Upgrade (ADNU) -- A transmission upgrade or addition identified by the CAISO to relieve an Area Deliverability Constraint.

Base Case -- The data including, but not limited to, base power flow, short circuit and stability data bases, underlying load, generation, and transmission facility assumptions, contingency lists, including relevant special protection systems, and transmission diagrams used to perform the Interconnection Studies. The Base Case may include Critical Energy Infrastructure Information (as that term is defined by FERC). The Base Case shall include transmission facilities as approved by the Distribution Provider or CAISO, as applicable, and Distribution Upgrades and Network Upgrades associated with generating facilities in (iv) below and generating facilities that (i) are directly interconnected to the Distribution System or CAISO Grid; (ii) are interconnected to Affected Systems and may have an impact on the Interconnection Request; (iii) have a pending request to interconnect to the Distribution System or an Affected System; or (iv) are not interconnected to the Distribution System or CAISO Grid, but are subject to a fully executed generator interconnection agreement (or its equivalent predecessor agreement) or for which an

unexecuted generator interconnection agreement (or its equivalent predecessor agreement) has been requested to be filed with FERC.

Breach -- The failure of a Party to perform or observe any material term or condition of the GIA.

Breaching Party -- A Party that is in Breach of the GIA.

Business Day -- Monday through Friday, excluding Federal Holidays and the Friday after Thanksgiving.

Calendar Day -- Any day including Saturday, Sunday or a Federal Holiday.

CAISO -- California Independent System Operator Corporation. See also ISO.

Clustering -- The process whereby a group of Interconnection Requests is studied together, instead of serially, for the purpose of conducting the Interconnection System Impact Study.

Commercial Operation -- The status of a Generating Facility that has commenced generating electricity for sale, excluding electricity generated during Trial Operation.

Commercial Operation Date -- The date on which an Electric Generating Unit at a Generating Facility has received final written Permission to Operate from the Distribution Provider for operation of the generation facilities in parallel with the utility.

Confidential Information -- Any confidential, proprietary or trade secret information of a plan, specification, pattern, procedure, design, device, list, concept, policy or compilation relating to the present or planned business of a Party, which is designated as confidential by the Party supplying the information, whether conveyed orally, electronically, in writing, through inspection, or otherwise.

Construction Activities -- Actions by the Distribution Provider that result in irrevocable financial commitments for the purchase of major electrical equipment or land for Distribution Provider's Interconnection Facilities, Distribution Upgrades, or Network Upgrades assigned to the Interconnection Customer that occur after receipt of all appropriate governmental approvals needed for the Distribution Provider's Interconnection Facilities, Distribution Upgrades, or Network Upgrades.

Control Area -- An electrical system or systems bounded by interconnection metering and telemetry, capable of controlling generation to maintain its interchange schedule with other Control Areas and contributing to frequency regulation of the interconnection. A Control Area must be certified by an Applicable Reliability Council.

CPUC -- California Public Utilities Commission.

Default -- The failure of a breaching Party to cure its Breach under the Small Generator Interconnection Agreement.

Deliverability -- (1) The annual Net Qualifying Capacity of a Generating Facility, as verified through a Deliverability assessment and measured in MW, which specifies the amount of resource adequacy capacity the Generating Facility is eligible to provide. (2) The annual Maximum Import Capability of an intertie, which specifies the amount of resource adequacy capacity, measured in MW, that Load-serving Entities collectively can procure from imports at that intertie to meet their resource adequacy requirements.

Deliverability Assessment -- An evaluation of the On-Peak Deliverability Assessment set forth in GIP Section 5.8.3, and the Off-Peak Deliverability Assessment set forth in GIP Section 5.8.3 to determine if a Generating Facility or a group of Generating Facilities could provide Energy to the CAISO Controlled Grid

and be delivered to the aggregate of Load on the CAISO Controlled Grid at Peak Load, under a variety of severely stressed conditions.

Deliverability Status -- An attribute of a Generating Facility that is requested by an Interconnection Customer for the Generating Facility, assigned by the CAISO to the Generating Facility through the GIP, GIDAP, or other process specified in the CAISO tariff, and that affects the maximum Net Qualifying Capacity to which the Generating Facility could be entitled.

Delivery Network Upgrades -- The transmission facilities at or beyond the point where the Distribution Provider's Distribution System interconnects to the ISO Grid, other than Reliability Network Upgrades, identified in the Interconnection Studies to relieve constraints on the ISO Grid. Delivery Network Upgrades may be further classified as Local Delivery Network Upgrades or Area Delivery Network Upgrades.

Dispute Resolution -- The procedure for resolution of a dispute between the Parties in which they will first attempt to resolve the dispute on an informal basis.

Distribution Owner -- The entity that owns, leases, or otherwise possesses an interest in the portion of the Distribution System at the Point of Interconnection and may be a Party to the Small Generator Interconnection Agreement to the extent necessary.

Distribution Provider -- The public utility (or its designated agent) that owns, controls, or operates transmission or distribution facilities used for the transmission of electricity in interstate commerce and provides transmission or wholesale distribution service under the Tariff. The term Distribution Provider should be read to include the Distribution Owner when the Distribution Owner is separate from the Distribution Provider.

Distribution Provider's Interconnection Facilities -- All facilities and equipment owned, controlled, or operated by the Distribution Provider from the Point of Change of Ownership to the Point of Interconnection as identified in the GIA, including any modifications, additions or upgrades to such facilities and equipment. Distribution Provider's Interconnection Facilities are sole use facilities and shall not include Distribution Upgrades, Stand Alone Network Upgrades or Network Upgrades.

Distribution Service -- The wholesale distribution service provided under the Tariff.

Distribution System -- Those non-ISO transmission and distribution facilities owned, controlled and operated by the Distribution Provider that are used to provide distribution service under the Tariff, which facilities and equipment are used to transmit electricity to ultimate usage points such as homes and industries directly from nearby generators or from interchanges with higher voltage transmission networks which transport bulk power over longer distances. The voltage levels at which Distribution Systems operate differ among areas.

Distribution Upgrades -- The additions, modifications, and upgrades to the Distribution Provider's Distribution System at or beyond the Point of Interconnection to facilitate interconnection of the Small Generating Facility and render the service necessary to effect the Interconnection Customer's wholesale sale of electricity in interstate commerce. Distribution Upgrades do not include Interconnection Facilities.

Effective Date -- The date on which the GIA becomes effective upon execution by the Parties subject to acceptance by FERC, or if filed unexecuted, upon the date specified by FERC.

Electric Generating Unit -- An individual electric generator and its associated plant and apparatus whose electrical output is capable of being separately identified and metered.

Emergency Condition -- A condition or situation: (1) that in the judgment of the Party making the claim is imminently likely to endanger life or property; or (2) that, in the case of a Distribution Provider, is

imminently likely (as determined in a non-discriminatory manner) to cause a material adverse effect on the security of, or damage to Distribution Provider's Distribution System, Distribution Provider's Interconnection Facilities or the electric systems of others to which the Distribution Provider's Distribution System is directly connected; or (3) that, in the case of Interconnection Customer, is imminently likely (as determined in a nondiscriminatory manner) to cause a material adverse effect on the security of, or damage to, the Generating Facility or Interconnection Customer's Interconnection Facilities. System restoration and black start shall be considered Emergency Conditions; provided that Interconnection Customer is not obligated by the GIA to possess black start capability.

Energy-Only Deliverability Status -- A condition elected by an Interconnection Customer for a Generating Facility interconnected to Distribution System, the result of which is that the Interconnection Customer is responsible only for the costs of Reliability Network Upgrades and is not responsible for the costs of Delivery Network Upgrades, but the Generating Facility will be deemed to have a Net Qualifying Capacity (as defined in the ISO Tariff) of zero and, therefore, cannot be considered to be a Resource Adequacy Resource (as defined in the ISO Tariff).

Engineering & Procurement (E&P) Agreement -- An agreement that authorizes the Distribution Provider to begin engineering and procurement of long lead-time items necessary for the establishment of the interconnection in order to advance the implementation of the Interconnection Request.

Environmental Law -- The applicable Laws or Regulations relating to pollution or protection of the environment or natural resources.

Federal Power Act -- The Federal Power Act, as amended, 16 U.S.C. §§ 791a et seq.

FERC -- The Federal Energy Regulatory Commission (Commission) or its successor.

Full Capacity Deliverability Status (FCDS) -- The condition whereby a Generating Facility interconnected with the Distribution System, under coincident ISO Control Area peak demand and a variety of severely stressed system conditions, can deliver the Generating Facility's full output to the aggregate of load on the ISO Grid, consistent with the ISO's reliability criteria and procedures and the ISO's On-Peak Deliverability Assessment.

Generating Facility -- The Interconnection Customer's device for the production and/or storage for later injection of electricity identified in the Interconnection Request, but shall not include the Interconnection Customer's Interconnection Facilities. A Small Generating Facility is one that has maximum capacity of 20 MW or less. A Large Generating Facility is one that has a maximum capacity of more than 20 MW.

Generating Facility Capacity -- The net capacity of the Generating Facility and the aggregate net capacity of the Generating Facility where it includes multiple Electric Generating Units.

Generator Interconnection Agreement (GIA) -- Either the Small Generator Interconnection Agreement (SGIA), which is Attachment F to the Wholesale Distribution Tariff, unless the proposed interconnection is for a generating facility larger than 20 MW, in which case references to interconnection agreement are to the Large Generator Interconnection Agreement (LGIA), which is Attachment H to the Wholesale Distribution Tariff.

Generator Interconnection and Deliverability Allocation Procedures (GIDAP) -- See ISO's Generator Interconnection and Deliverability Allocation Procedures (ISO Tariff GIDAP)

Generator Interconnection Procedures (GIP) -- See the definition for either ISO's Tariff Generator Interconnection Procedures (ISO Tariff GIP), or Wholesale Distribution Tariff Generator Interconnection Procedures (WDT GIP).

Good Utility Practice – Any of the practices, methods and acts engaged in or approved by a significant portion of the electric industry during the relevant time period, or any of the practices, methods and acts which, in the exercise of reasonable judgment in light of the facts known at the time the decision was made, could have been expected to accomplish the desired result at a reasonable cost consistent with good business practices, reliability, safety and expedition. Good Utility Practice is not intended to be limited to the optimum practice, method, or act to the exclusion of all others, but rather to be acceptable practices, methods, or acts generally accepted in the region.

Governmental Authority – Any federal, state, local or other governmental regulatory or administrative agency, court, commission, department, board, or other governmental subdivision, legislature, rulemaking board, tribunal, or other governmental authority having jurisdiction over the Parties, their respective facilities, or the respective services they provide, and exercising or entitled to exercise any administrative, executive, police, or taxing authority or power; provided, however, that such term does not include the Interconnection Customer, the Interconnection Provider, or any Affiliate thereof.

Initial Synchronization Date -- The date upon which the Generating Facility is initially synchronized and upon which Trial Operation begins.

In-Service Date -- The date upon which the Interconnection Customer reasonably expects it will be ready to begin use of the Distribution Provider's Interconnection Facilities to obtain back feed power.

Interconnection Customer – Any entity, including the Distribution Provider, the Distribution Owner, the Transmission Owner or any of the affiliates or subsidiaries of either, that proposes to interconnect its Small Generating Facility with the Distribution Provider's Distribution System.

Interconnection Customer's Interconnection Facilities – All facilities and equipment, as identified in the GIA, that are located between the Generating Facility and the Point of Change of Ownership, including any modification, addition, or upgrades to such facilities and equipment necessary to physically and electrically interconnect the Generating Facility to the Distribution Provider's Distribution System. Interconnection Customer's Interconnection Facilities are sole use facilities.

Interconnection Facilities – The Distribution Provider's Interconnection Facilities and the Interconnection Customer's Interconnection Facilities. Collectively, Interconnection Facilities include all facilities and equipment between the Small Generating Facility and the Point of Interconnection, including any modification, additions or upgrades that are necessary to physically and electrically interconnect the Small Generating Facility to the Distribution Provider's Distribution System. Interconnection Facilities are sole use facilities and shall not include Distribution Upgrades or Network Upgrades.

Interconnection Financial Security -- The financial instrument(s) submitted by the Interconnection Customer to the Distribution Provider prior to the start of any Construction Activities as a security for the Distribution Provider against the estimated costs of the Construction Activities described in the Generator Interconnection Agreement. The Interconnection Customer may post the Interconnection Financial Security using any of the financial instruments listed in the WDT GIP.

Interconnection Handbook - A handbook, developed by the Distribution Provider and posted on the Distribution Provider's website or otherwise made available by the Distribution Provider, describing the technical and operational requirements for wholesale generators and loads connected to the Distribution System, as such handbook may be modified or superseded from time to time. In the event of a conflict between the terms of this SGIA and the terms of the Distribution Provider's Interconnection Handbook, the terms in this SGIA shall govern.

Interconnection Request – The Interconnection Customer's request, in accordance with the Tariff, to interconnect a new Small Generating Facility, or to increase the capacity of, or make a Material Modification to the operating characteristics of, an existing Small Generating Facility that is interconnected with the Distribution Provider's Distribution System.

Interconnection Service -- The service provided by the Distribution Provider associated with interconnecting the Interconnection Customer's Generating Facility to the Distribution Provider's Distribution System and enabling it to receive electric energy and capacity from the Generating Facility at the Point of Interconnection, pursuant to the terms of the GIA and, if applicable, the Distribution Provider's Tariff.

IRS -- The Internal Revenue Service.

ISO -- The California Independent System Operator Corporation, a state chartered, nonprofit, corporation that controls certain transmission facilities of all Participating Transmission Owners and dispatches certain generating units and loads. See also CAISO.

ISO Grid -- The system of transmission lines and associated facilities of the Participating Transmission Owners that have been placed under the ISO's Operational Control.

ISO's Generator Interconnection and Deliverability Allocation Procedures (ISO Tariff GIDAP) -- The procedures included in the ISO Tariff to interconnect a Generating Facility directly to the ISO Grid, as such procedures may be modified from time to time, and accepted by the Commission. See also GIDAP.

ISO's Generator Interconnection Procedures (ISO Tariff GIP) -- The procedures included in the ISO Tariff to interconnect a Generating Facility directly to the ISO Grid, as such procedures may be modified from time to time, and accepted by the Commission. See also GIP.

Large Generating Facility -- A Generating Facility having a Generating Facility Capacity of more than 20 MW.

Local Deliverability Constraint -- A transmission system operating limit modeled in the GIDAP study process that would be exceeded if the CAISO were to assign Full Capacity Deliverability Status or Partial Capacity Deliverability Status to one or more additional Generating Facilities interconnecting to the CAISO Controlled Grid in a specific local area, and that is not an Area Deliverability Constraint.

Local Delivery Network Upgrade (LDNU) -- A transmission upgrade or addition identified by the CAISO in the GIDAP Interconnection Study Process to relieve a Local Deliverability Constraint.

Loss -- Any and all losses relating to injury to or death of any person or damage to property, demand, suits, recoveries, costs and expenses, court costs, attorney fees, and all other obligations by or to third parties, arising out of or resulting from the other Party's performance, or non-performance of its obligations under the GIA on behalf of the indemnifying Party, except in cases of gross negligence or intentional wrongdoing by the indemnifying Party.

Material Modification -- A modification that has a material impact on the cost or timing of any Interconnection Request, or any other valid interconnection request to the Distribution Provider or the ISO with a later queue priority date.

Metering Equipment -- All metering equipment installed or to be installed at the Generating Facility pursuant to the GIA at the metering points, including but not limited to instrument transformers, MWh-meters, data acquisition equipment, transducers, remote terminal unit, communications equipment, phone lines, and fiber optics.

NERC -- The North American Electric Reliability Council or its successor organization.

Network Upgrades – Additions, modifications, and upgrades to the Distribution Provider's Transmission System required at or beyond the point at which the Distribution System connects to the Distribution Provider's Transmission System to accommodate the interconnection of the Small Generating Facility to the Distribution Provider's Distribution System. Network Upgrades do not include Distribution Upgrades. See also: **Area Delivery Network Upgrades; Delivery Network Upgrades; Local Delivery Network Upgrades; and Reliability Network Upgrades.**

Notice of Dispute -- A written notice of a dispute or claim that arises out of or in connection with the GIA or its performance.

Operating Requirements – Any operating and technical requirements that may be applicable due to Regional Transmission Organization, California Independent System Operator, control area, or the Distribution Provider's requirements, including those set forth in the Small Generator Interconnection Agreement.

Participating Transmission Owner -- An entity which (i) owns, operates, and maintains transmission lines and associated facilities and/or has entitlements to use certain transmission lines and associated facilities; and (ii) has transferred to the ISO operational control of such facilities and/or entitlements to be made part of the ISO Grid.

Party or Parties – The Distribution Provider, Distribution Owner, Transmission Owner, Interconnection Customer or any combination of the above.

Point of Change of Ownership -- The point set forth in the GIA where the Interconnection Customer's Interconnection Facilities connect to the Distribution Provider's Interconnection Facilities.

Point of Interconnection – The point set forth in the GIA where the Interconnection Facilities connect with the Distribution Provider's Distribution System.

Pre-Construction Activities -- The actions by the Distribution Provider, other than those required by an Engineering and Procurement Agreement under Section 8 of the GIP, undertaken prior to Construction Activities in order to prepare for the construction of the Distribution Provider's Interconnection Facilities, Distribution Upgrades, or Network Upgrades assigned to the Interconnection Customer, including, but not limited to, preliminary engineering, permitting activities, environmental analysis, or other activities specifically needed to obtain governmental approvals for the Distribution Provider's Interconnection Facilities, Distribution Upgrades, or Network Upgrades.

Qualifying Capacity -- The maximum Resource Adequacy Capacity that a Resource Adequacy Resource may be eligible to provide. The criteria and methodology for calculating the Qualifying Capacity of resources may be established by the CPUC or other applicable Local Regulatory Authority and provided to the CAISO. A resource's eligibility to provide Resource Adequacy Capacity may be reduced below its Qualifying Capacity through the CAISO's assessment of Net Qualifying Capacity.

Queue Position – The order of a valid Interconnection Request, relative to all other pending valid Interconnection Requests, that is established based upon the date and time of receipt of the valid Interconnection Request by the Distribution Provider and is represented by a unique identifying code assigned to each Interconnection Request that is deemed complete.

Reasonable Efforts – With respect to an action required to be attempted or taken by a Party under the Small Generator Interconnection Agreement, efforts that are timely and consistent with Good Utility Practice and are otherwise substantially equivalent to those a Party would use to protect its own interests.

Reliability Network Upgrades -- The transmission facilities at or beyond the point where the Distribution Provider's Distribution System interconnects to the ISO Grid, necessary to interconnect one or more Generating Facility(ies) safely and reliably to the ISO Grid, which would not have been necessary but for

the interconnection of one or more Generating Facility(ies), including Network Upgrades necessary to remedy short circuit or stability problems, or thermal overloads. Reliability Network Upgrades shall only be deemed necessary for thermal overloads, occurring under any system condition, where such thermal overloads cannot be adequately mitigated through the ISO's congestion management, operating procedures, or special protection systems based on the characteristics of the Generating Facilities included in the Interconnection Studies, limitations on market models, systems, or information, or other factors specifically identified in the Interconnection Studies. Reliability Network Upgrades also include, consistent with the Applicable Reliability Council's practice and Applicable Reliability Standards, the facilities necessary to mitigate any adverse impact the Generating Facility's interconnection may have on a path's Applicable Reliability Council rating.

Resource Adequacy (RA) -- A mandatory planning and procurement process to ensure adequate resources to serve all customers in real time. The program requires that Load Serving Entities (LSEs) meet a Planning Reserve Margin for their obligations. The program provides deliverability criteria that each LSE must meet, as well as system and local capacity requirements. Rules are provided for "counting" resources towards meeting resource adequacy obligations. The resources that are counted for RA purposes must make themselves available to the California ISO for the capacity for which they were counted. The ISO's Interim Reliability Requirements Program and the resource adequacy under MRTU tariff provisions are intended to complement the State of California's efforts to implement resource adequacy programs.

Site Control -- Documentation reasonably demonstrating: (1) ownership of, a leasehold interest in, or a right to develop a site for the purpose of constructing the Generating Facility; (2) an option to purchase or acquire a leasehold site for such purpose; or (3) an exclusivity or other business relationship between Interconnection Customer and the entity having the right to sell, lease or grant Interconnection Customer the right to possess or occupy a site for such purpose (see also: Site Exclusivity).

Site Exclusivity -- The third option to prove Site Control and applies only in instances when the Interconnection Customer has a business (private) or government agency (public) relationship with the project site's deed holder.

- (1) For private land, Site Exclusivity shall mean documentation reasonably demonstrating legal authorization from the land owner showing the Interconnection Customer has either (a) Ownership of, a leasehold interest in, or a right to develop property upon which the Generating Facility will be located consisting of a minimum of 50% of the acreage reasonably necessary to accommodate the Generating Facility; or (b) an option to purchase or acquire a leasehold interest in property upon which the Generating Facility will be located consisting of a minimum of 50% of the acreage reasonably necessary to accommodate the Generating Facility.
- (2) For public land, including that controlled or managed by any federal, state or local agency, Site Exclusivity shall mean documentation from the governing public agency providing a final, non-appealable permit, license, or other exclusive legal right to use the property for the purpose of generating electric power and in acreage reasonably necessary to accommodate the Generating Facility. Such documentation showing exclusive right to use public land under the management of a Local, State, or Federal agency shall be in a form specified by that agency.

Smart Inverter —A Generating Facility's inverter that performs functions that when activated can autonomously contribute to grid support during excursions from normal operating voltage and frequency system conditions by providing dynamic reactive/real power support, voltage and frequency ride-through, ramp rate controls, communication systems with ability to accept external commands and other functions.

Small Generating Facility – An Interconnection Customer's device for the production and/or storage for later injection of electricity identified in the Interconnection Request, but shall not include the Interconnection Customer's Interconnection Facilities, that has a generating capacity of 20 megawatts (MW) or less.

Stand Alone Network Upgrades -- Network Upgrades that an Interconnection Customer may construct without affecting day-to-day operations of the Transmission System during their construction. Both the Distribution Provider and the Interconnection Customer must agree as to what constitutes Stand Alone Network Upgrades and identify them in an Appendix to the GIA.

System Protection Facilities -- The equipment, including necessary protection signal communications equipment, required to protect (1) the Distribution Provider's Distribution System, the ISO Controlled Grid, and Affected Systems from faults or other electrical disturbances occurring at the Generating Facility and (2) the Generating Facility from faults or other electrical system disturbances occurring on the Distribution Provider's Distribution System, the ISO Controlled Grid or on other delivery systems or other generating systems to which the Distribution Provider's Distribution System and Transmission System is directly connected.

Tariff -- The Distribution Provider's Wholesale Distribution Tariff through which open access distribution service and Interconnection Service are offered, as filed with the FERC, and as amended or supplemented from time to time, or any successor tariff.

Transmission System -- Those facilities owned by the Distribution Provider that have been placed under the ISO's operational control and are part of the ISO Grid.

Trial Operation -- The period during which Interconnection Customer is engaged in on-site test operations and commissioning of the Generating Facility prior to Commercial Operation. Also known as Permission to Parallel for Test Purposes.

Uncontrollable Force -- Any act of God, labor disturbance, act of the public enemy, war, insurrection, riot, fire, storm, flood, earthquake, explosion, breakage or accident to machinery or equipment, any curtailment, order, regulation or restriction imposed by governmental, military or lawfully established civilian authorities, or any other cause beyond the reasonable control of the Distribution Provider or Interconnection Customer which could not be avoided through the exercise of Good Utility Practice. An Uncontrollable Force event does not include acts of negligence or intentional wrongdoing by the Party claiming Uncontrollable Force.

Upgrades -- The required additions and modifications to the Distribution Provider's Distribution System, at or beyond the Point of Interconnection. Upgrades may be Network Upgrades or Distribution Upgrades. Upgrades do not include Interconnection Facilities.

Wholesale Distribution Tariff Generator Interconnection Procedures (WDT GIP) -- The procedures included in the Distribution Provider's Wholesale Distribution Tariff (WDT) to interconnect a Generating Facility directly to the Distribution Provider's Distribution System, as such procedures may be modified from time to time, and accepted by the Commission.

Attachment 2**Description and Costs of the Small Generating Facility, Interconnection Facilities and Metering Equipment**

Central Coast Community Energy, an Interconnection Customer (IC), has requested a Generating Facility (GF) interconnection for Emeline (Project) to the Pacific Gas and Electric Company (PG&E)'s distribution system for a 3000 kW BESS generating facility to be located at 1000 Emeline Ave, SANTA CRUZ, CA 95060. The Generating Facility will be connected to PG&E's Paul Sweet 2105 distribution circuit. Interconnection will be in accordance with FERC's Generator Interconnection Procedures. The requested operating date for the Project is 30 April 2024. This Project has been assigned the reference number of 3243-WD.

Equipment, including the Small Generating Facility, Interconnection Facilities, and metering equipment shall be itemized and identified as being owned by the Interconnection Customer, the Distribution Provider, Distribution Owner or the Transmission Owner. The Distribution Provider will provide a best estimate itemized cost, including overheads, of its Interconnection Facilities and metering equipment, and a best estimate itemized cost of the annual operation and maintenance expenses associated with its Interconnection Facilities and metering equipment.

Actual costs incurred by the Interconnection Customer to install these Interconnection Facilities will be trued up with the Interconnection Customer once this project has achieved commercial operation, per Article 6.1 of this agreement. The Interconnection Customer will be responsible for payment of all actual costs incurred to install these facilities, and any additional facilities identified as necessary during the engineering, design, or construction phases. Should additional facilities be deemed necessary for the interconnection of this facility, Distribution Provider will identify these additional facilities as soon as possible in the construction phase, and will coordinate with the Interconnection Customer on the additional costs and timing needed to implement them. As needed, the costs of ownership for these Interconnection Facilities also will be updated once this project has achieved commercial operation.

Project Information

Project Name:	Emeline
Number of Generators:	4 BESS
Manufacturer Model Name & Number:	SolBank S1K5650A01 or similar battery energy storage container
Number of Inverters:	2
Manufacturer Model Name & Number:	EPC Power CAB1000 (50-100181 [600V])
Total Output:	3000 kVA (3000kW @ 1.0 power factor)
Transformer Data:	3000 kVA @ Z = 5.75% 21kV / 600V Delta / Wye-Grounded
PG&E Grid Voltage at Interconnection:	21 kV
Substation / Feeder	Paul Sweet Bank 2 115kV / 21.6kV Paul Sweet 2105
Primary Line Configuration at POI	3-phase, 4-wire distribution circuit
Description of Operation	Wholesale export to Paul Sweet 2105
Energy Storage Load Study Option	Firm Service
Load	Unrestricted charging (3MW of battery charging at any time or any day of the year).

Interconnection Facilities

The estimated costs associated with the Interconnection Facilities required to interconnect the project to Distribution Provider's Distribution System.

Interconnection Facilities (Subject to Cost-of-Ownership)	Costs
Pre-energization test, protection review and testing witnessing	\$10,000
PG&E Primary Revenue Metering	\$15,000
Primary Service-OH (Per location not including Metering)	\$15,000
PG&E SCADA Recloser at POI	\$80,000
Total -- Interconnection Facility Costs (Subject to Cost-of-Ownership)	\$ 120,000
ITCC Tax ¹	TBD

In Process

¹ Not subject to ITCC (Income Tax Calculation Component) on contribution. ITCC is exempt for wholesale generators that meet the IRS Safe Harbor Provisions. PG&E currently does not require the Interconnection Customer to provide security to cover the potential tax liability on the Interconnection Facilities, Distribution Upgrades, and Network Upgrades per the IRS Safe Harbor Provisions (IRS Notice 88-129). PG&E reserves the right to require, on a nondiscriminatory basis, the Interconnection Customer to provide such security, in a form reasonably acceptable to PG&E as indicated in Article 11 of the SGIA, an amount up to the cost consequences of any current tax liability. Upon request and within sixty (60) Calendar Days' notice, the Interconnection Customer shall provide PG&E such ITCC security or ITCC payment in the event that Safe Harbor Provisions have not been met, in the form requested by PG&E.

One-line Diagram Depicting the Small Generating Facility, Interconnection Facilities, Metering Equipment, and Upgrades

Figure 3-1 One-Line Conceptual Diagram of Emeline

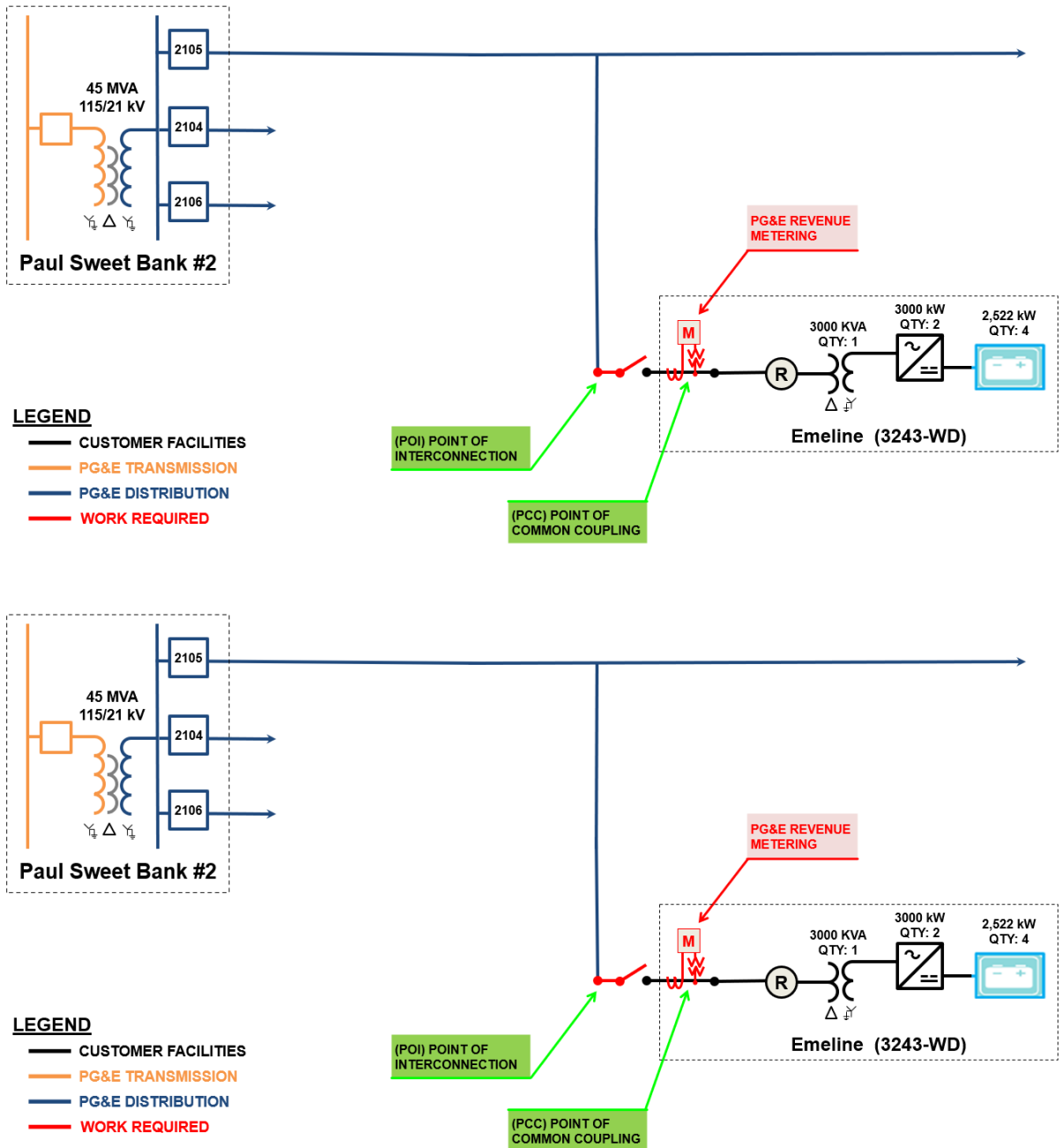

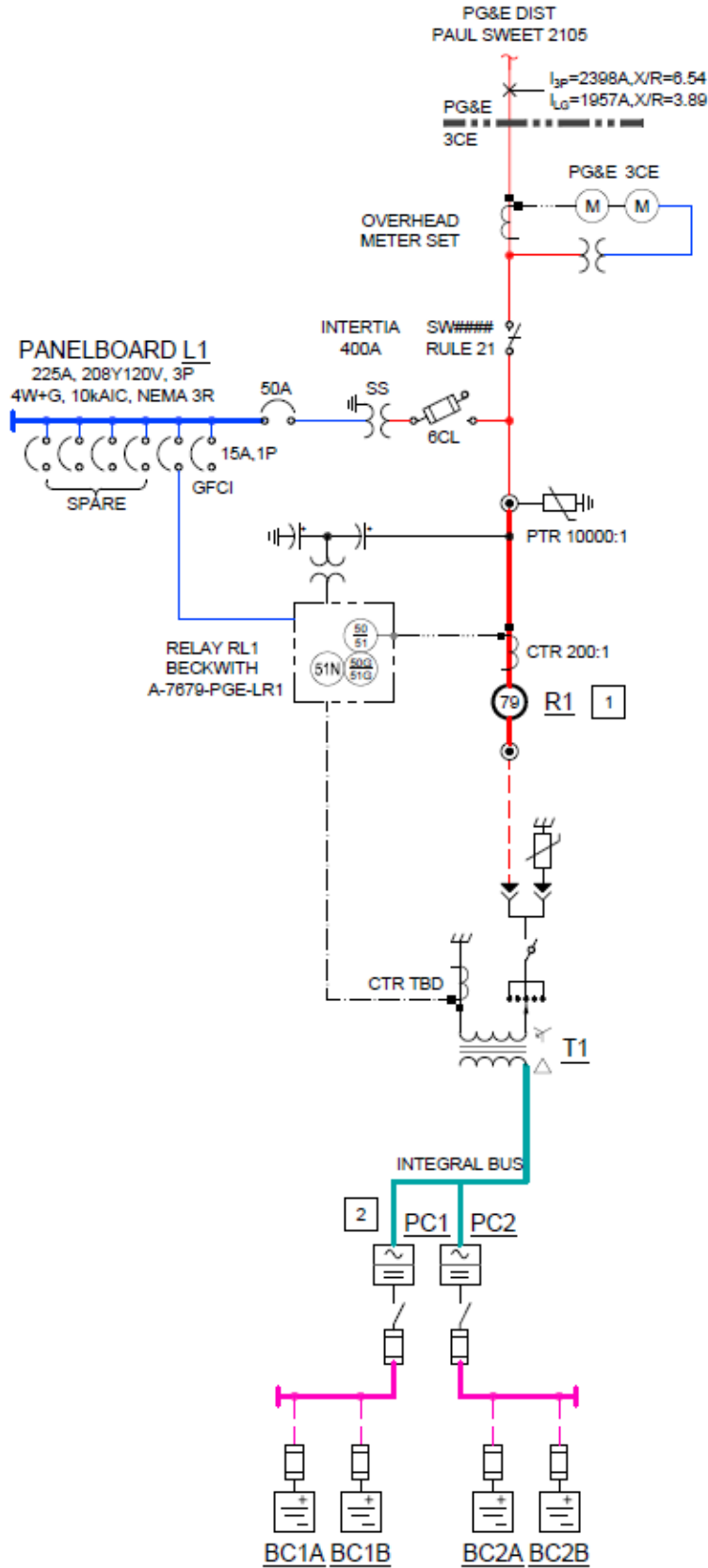

Figure 3-2 Vicinity Map of Emeline



Attachment 4**Milestones****In-Service Date:** February 5, 2025

Critical milestones and responsibility as agreed to by the Parties:

	Milestone	Date	Responsible Party
1	Financial Security Posting Due Date	January 22, 2024	Interconnection Customer
2	Initiate Pre-Construction Activities <i>(EGI will request the beginning of estimation and design. Beginning of expenditures against Financial Security.)</i>	February 22, 2024	Distribution Provider
3	Submit electronic initial design package <i>(including but not limited to equipment list, 70% final SLD, site map and site plan)</i>	January 29, 2024	Interconnection Customer
4	On-site project kick-off meeting	February 19, 2024	Distribution Provider & Interconnection Customer
5	Completion of the Interconnection Facilities, Distribution Upgrades, and Network Upgrade facilities	January 22, 2025	Distribution Provider & Interconnection Customer
6	In-Service Date (back-feed power)	February 5, 2025	Distribution Provider & Interconnection Customer
7	Pre-parallel Inspection and Testing	March 5, 2025	Distribution Provider & Interconnection Customer
8	Initial Synchronization	March 19, 2025	Interconnection Customer
9	Provide written approval to Interconnection Customer for the operation of the facilities (PTO) and Commercial Operation Date (COD)	March 26, 2025	Distribution Provider
10	Completion of Reliability and Deliverability Network Upgrades (RNU, DNU) identified in Attachment 5 as part of implementing FCDS	N/A	Distribution Provider

Note 1 – Ability to Meet Milestone Dates

The ability to meet these Milestone dates requires that all tasks, including tasks preceding the milestones listed above, to be completed in a timely fashion and does not account for unanticipated delays, including but not limited to delays caused by: emergency response due to wildfires or storms; time to complete environmental studies; availability of needed resources (e.g., materials or crews); difficulties securing necessary permits, easements, right of ways, licenses or other approvals; construction additional information needed to complete the project implementation process; or delays scheduling clearances to complete the interconnection of this project to the PG&E system.

Note 2 -- Supplemental Billing and Payment Provisions:

In accordance with Article 6.3 of this project's SGIA, the financial security posting(s) must be completed by the Interconnection Customer before the Distribution Provider may begin any capital work. The Interconnection Customer may negotiate a milestone date to post the financial security(-ies) up to 180

Calendar Days (CD) after the execution of this SGIA. This negotiated date is shown in the milestones table above. If the financial security posting(s) is/are not completed by the date shown in the table above, a notice of default will be issued to the Interconnection Customer in accordance with Article 7.6 of this SGIA.

Note 3 -- Billing Procedures for Actual Costs:

Per Section 6.1.1 of this project's SGIA, PG&E will bill the Interconnection Customer on a monthly basis for actual labor and/or material costs incurred during the prior month.

Agreed to by:

For the Distribution Provider

DocuSigned by:
Michael Porter
4A75504861C3402...

Date: 7/20/2023 | 8:48:47 PDT

For the Interconnection Customer

DocuSigned by:
Robert Shaw
398728BE39B342A...

Date: 8/9/2023 | 3:35:34 PDT

In Process

**Additional Operating Requirements for the Distribution Provider's Distribution System,
Transmission System and Affected Systems Needed to Support
the Interconnection Customer's Needs**

5.1 General Operating Requirements

The Distribution Provider shall also provide requirements that must be met by the Interconnection Customer prior to initiating parallel operation with the Distribution Provider's Distribution System.

At a minimum, the Interconnection Customer agrees to construct and interconnect the facility described in this agreement with the PG&E system in accordance with the standards and requirements described in the PG&E Transmission Interconnection Handbook (TIH) and the Distribution Interconnection Handbook (DIH), as well as any specific operating requirements identified and described in the final interconnection study completed by the Distribution Provider for this facility.

5.2 Deliverability Status

The Interconnection Customer has elected for this Small Generating Facility to have Energy Only Deliverability Status, as defined in the CAISO Tariff. As a result, this Small Generating Facility was studied for Energy Only Deliverability Status by the Distribution Provider, and the results of those studies have been incorporated into this SGIA. The Interconnection Customer and the Distribution Provider acknowledge and understand that this Small Generating Facility will have Energy Only Deliverability Status.

In Process

Attachment 6**Distribution Provider's Description of its Upgrades
and Best Estimate of Upgrade Costs**

The Distribution Provider shall describe Upgrades and provide an itemized best estimate of the cost, including overheads, of the Upgrades and annual operation and maintenance expenses associated with such Upgrades. The Distribution Provider shall functionalize Upgrade costs and annual expenses as either transmission or distribution related.

Actual costs incurred by the Interconnection Customer to install these Distribution Upgrades and Network Upgrades will be trued up with the Interconnection Customer once this project has achieved commercial operation, per Article 6.1 of this agreement. The Interconnection Customer will be responsible for payment of all actual costs incurred to install these facilities, and any additional facilities identified as necessary during the engineering, design, or construction phases. Should additional upgrades be deemed necessary for the interconnection of this facility, Distribution Provider will identify these additional upgrades as soon as possible in the construction phase, and will coordinate with the Interconnection Customer on the additional costs and timing needed to implement them. As needed, the costs of ownership for these Interconnection Facilities also will be updated once this project has achieved commercial operation.

Distribution Upgrades

The estimated costs associated with the system upgrades required to interconnect the project to the Distribution Provider's Distribution System.

Distribution Upgrades: None

Reliability Network Upgrades

The estimated costs associated with the system upgrades required to interconnect the project to the Distribution Provider's Transmission System. In accordance with Article 5.2.1 of this Agreement, Reliability Network Upgrades reimbursement is capped at a maximum of \$TBD per MW of generating capacity. To the extent that such reimbursement does not cover all costs of the RNUs, the IC shall receive Congestion Revenue Rights ("CRRs") for the portion of the RNUs that are not covered by the above reimbursement.

Reliability Network Upgrades: None

Total Project Costs

Cost Category	Amount Subject to COO (\$)	Amount NOT Subject to COO (\$)	Total Cost Category Amount (\$)
Interconnection Facilities Costs (Attachment 2)	\$120,000	N/A	\$120,000
Distribution Upgrade Costs (Attachment 6)	\$0	N/A	\$0
Network Upgrade Costs			
Reliability Network		\$	\$

Upgrade Costs (Attachment 6)			
Deliverability-related RNU (Attachment 5)	N/A	\$	\$
Delivery Network Upgrades (Attachment 5)	N/A	\$	\$
Total Project Costs (\$)	\$120,000	\$	\$120,000

Total Cost-of-Ownership Charges for Project:

The Interconnection Customer has elected the following by placing a check mark against it for Cost-of-Ownership for the applicable Interconnection Facilities and/or Distribution Upgrades. The Cost-of-Ownership will commence upon the In-Service Date per Article 4.1.2.

A. **Monthly Cost-of-Ownership Charge**

$$\text{\$ } 120,000 \times 0.89\%^2 \text{ (current percentage rate) = \text{\$ } 1,068$$

Total Monthly Cost-of-Ownership Charge	\\$ 1,068 / month
---	--------------------------

B. **Equivalent One-Time Charge** (in lieu of recurring Monthly Cost-of-Ownership Charge)

$$\text{\$ } 1,068 / \text{ month} \times 12 \text{ months} \times 14.73 \text{ (present worth factor}^3\text{) = \text{\$ } 188,779.68$$

Total Equivalent One-Time Charge	\\$ 188,779.68
---	-----------------------

² The COST-OF-OWNERSHIP Charge for Interconnections provided under this Agreement is determined in accordance with PG&E's applicable percentage rates calculated using PG&E's most recent distribution owner revenue requirement on file with and accepted by FERC. PG&E currently charges the following COST-OF-OWNERSHIP rates for distribution facilities: Customer financed, Distribution-level Rate of 0.89% monthly.

³ The Present Worth Factor (PWF), which is also known as the perpetuity factor, is used under this agreement to determine the equivalent One-Time Payment. This financial factor is the reciprocal of the after-tax Rate of Return on Rate Base (ROR). The after-tax ROR is calculated by the Economic and Project Analysis Department and is based on CPUC decisions, which establish the Return on Rate Base.